

THIS DRAWING IS UNPUBLISHED. RELEASED FOR PUBLICATION
 © COPYRIGHT BY TYCO ELECTRONICS CORPORATION. ALL RIGHTS RESERVED.

LOC		DIST		REVISIONS			
P	LTR	DESCRIPTION	DATE	DWN	APVD		
0		RELEASED.	20JUN2005	JGH	JGH		
01		REVISED PER ECO-09-024606	03NOV09	KK	AEG		

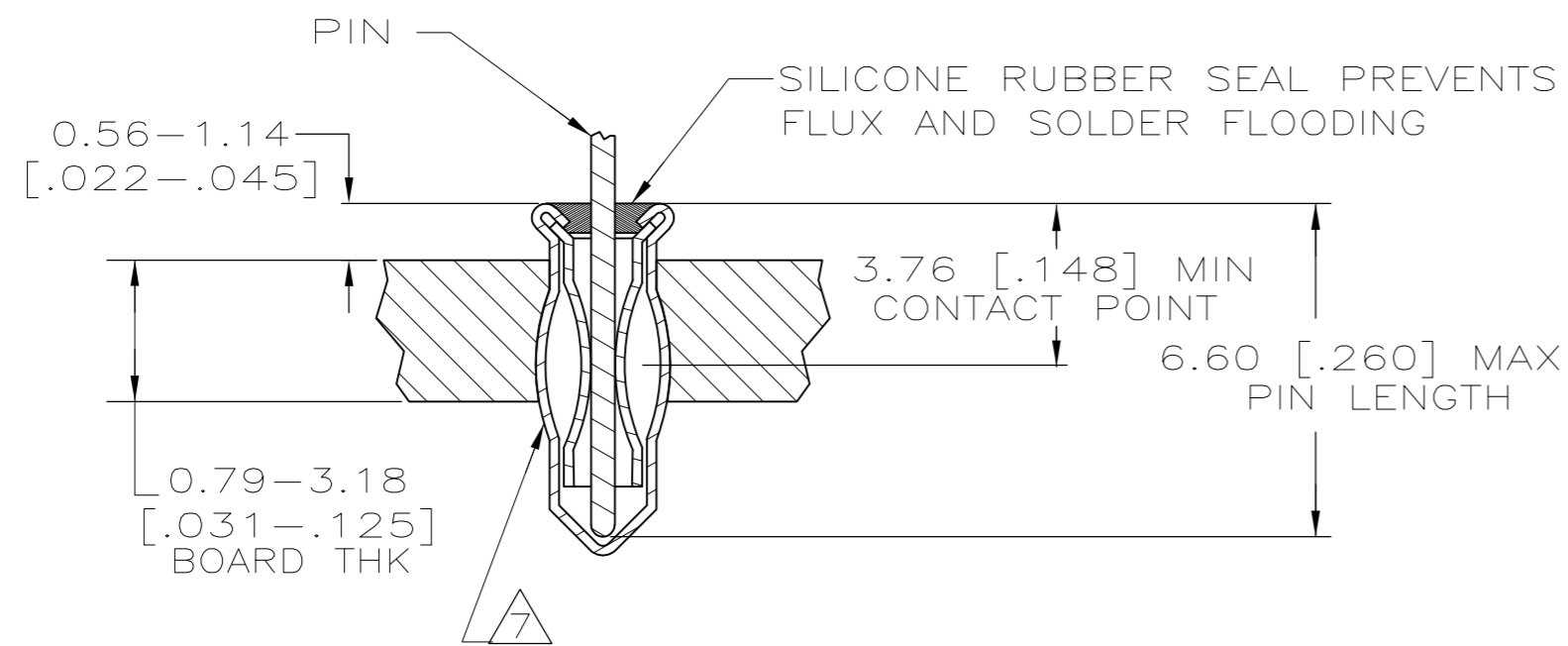
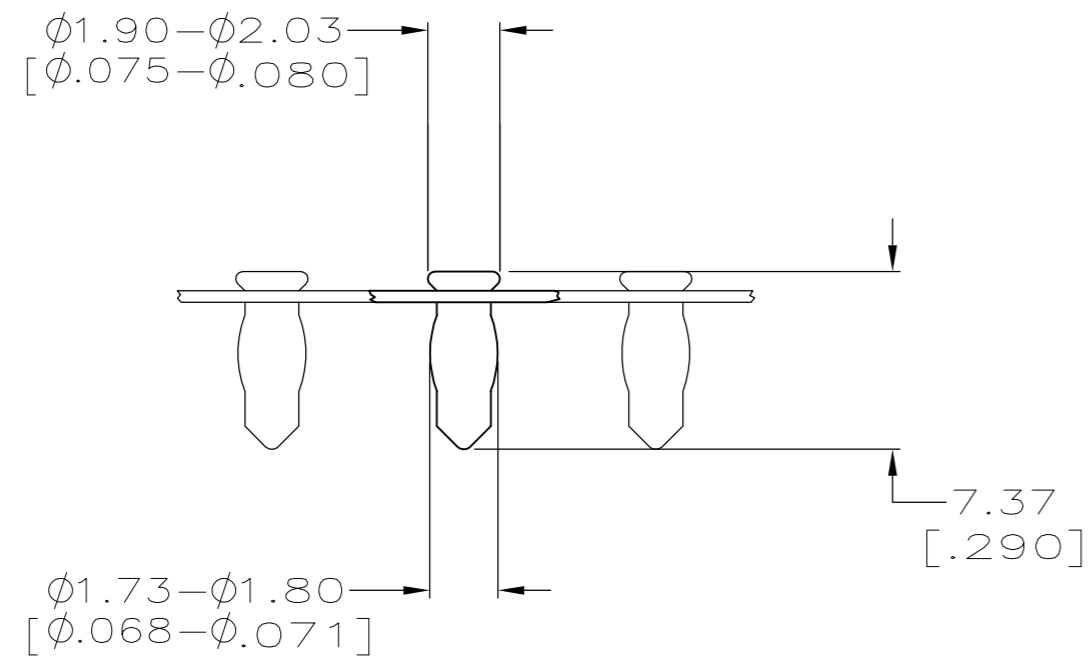
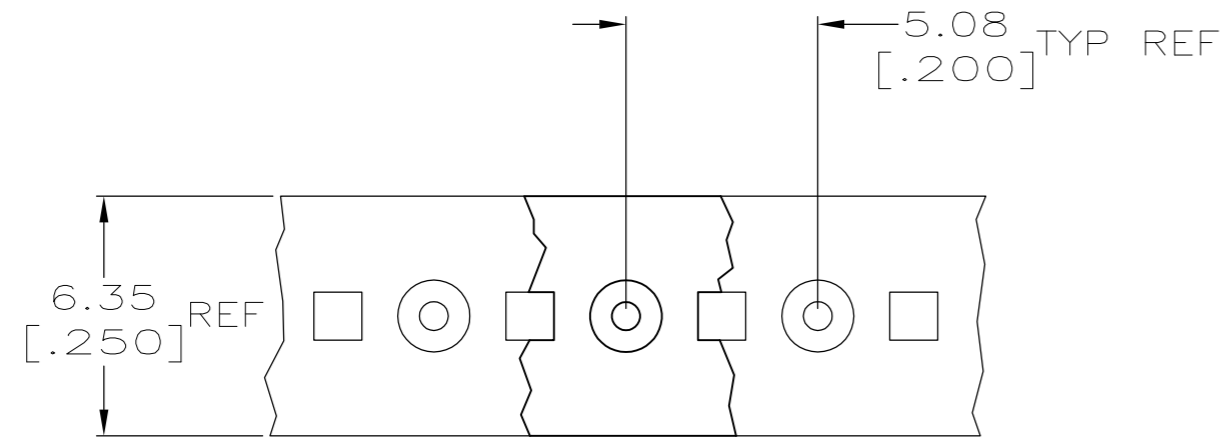

- 1 MATERIAL:
 EYELET - COPPER PER ASTM B 152
 SPRING - BERYLLIUM COPPER PER ASTM B 194
 SEALANT - SILICONE RUBBER
- 2 TIN PLATE PER ASTM B 545 0.00381 [.000150] MIN THK.
- 3 TIN PLATE PER ASTM B 545 0.00254 [.000100] MIN THK.
- 4 GOLD PLATE PER ASTM B 488 0.00076 [.000030] MIN THK ON CONTACT AREA.
- 5 PACKAGED 50,000 PER REEL
- 6 TO INSURE 1/2 OZ MIN RETENTION DO NOT EXCEED 0.10 [.004] DIFFERENCE IN PIN DIA WHEN CHANGING TO A SMALLER DIA PIN
- 7 PRODUCT IS OVALIZED FOR RETENTION IN THE P.C. BOARD. THE RECOMMENDED HOLE DIAMETER IS $\phi 1.57$ [$\phi 0.062$] MINIMUM, +0.08 [.003] MAX. PRIOR TO SOLDERING.
- 8 PACKAGED 10,000 PER REEL
- 9 OBSOLETE PARTS: OBSOLETE CIS STREAMLINING PER D.RENAUD/D.SINISI

	3.76-6.60 [.148-.260]	$\phi 0.71 - \phi 0.84$ [$\phi 0.028 - \phi 0.033$]	GOLD 4	TIN 2	8 1-5645986-2
	3.76-6.60 [.148-.260]	$\phi 0.71 - \phi 0.84$ [$\phi 0.028 - \phi 0.033$]	TIN 3	TIN 2	8 1-5645986-1
9 OBSOLETE	3.76-6.60 [.148-.260]	$\phi 0.71 - \phi 0.84$ [$\phi 0.028 - \phi 0.033$]	GOLD 4	TIN 2	5 5645986-2
	LENGTH	DIA 6	SPRING	EYELET	PART NO.
	PIN		FINISH		

THIS DRAWING IS A CONTROLLED DOCUMENT.		DWN J. HAVENER 20JUN2005	Tyco Electronics Corporation Harrisburg, Pa 17105-3608		
DIMENSIONS: mm [INCHES]		CHK J. HAVENER 20JUN2005	NAME MINIATURE SPRING SOCKET ASSY SERIES 3 WITH SEALANT		
TOLERANCES UNLESS OTHERWISE SPECIFIED:		APVD J. HAVENER 20JUN2005	SIZE A2	CAGE CODE 00779	DRAWING NO C=5645986
0 PLC ± -		PRODUCT SPEC -	RESTRICTED TO -		
1 PLC ± -		APPLICATION SPEC -			
2 PLC ± -		WEIGHT -			
3 PLC ± 0.20[.008]		CUSTOMER DRAWING	SCALE 10:1	SHEET 1 OF 1	REV 01
4 PLC ± -					
ANGLES ± -					
FINISH SEE TABLE					

CUSTOMER DRAWING